



IOT-ENABLED SMART STREET LIGHTING WITH INTEGRATED EV CHARGING HUB



B. Vijaya Lakshmi¹, K. Rakshetha Goud², N. Jhansi³, G. Jayasree⁴

Original Article

¹Assistant Professor, Department of Electrical and Electronics Engineering, Stanley College of Engineering and Technology for Women, Hyderabad

^{2,3,4}UG Scholar, Department of Electrical and Electronics Engineering, Stanley College of Engineering and Technology for Women, Hyderabad

*Corresponding Author's Email: vijaya1105@stanley.edu.in¹, rakshethagoud@gmail.com², jhansineerudi@gmail.com³, jayasreeguguloth2003@gmail.com⁴

Abstract

This project talks about creating a smart street light system that uses renewable energy, specifically solar power and piezoelectric energy. The energy produced is kept in a 12volt lead-acid battery and controlled to provide power to an Arduino microcontroller. The LDR sensor checks how bright it is outside, and the IR sensor looks for cars or people nearby. The Arduino uses signals from sensors to turn on and off a 12-volt LED street light automatically through a relay. The system lowers energy use by turning on the light just when it's needed. A portable charging port is also included for extra convenience. The system suggested is affordable, uses less energy, and works well in smart city environments.

Index Terms—*Smart Street Lighting, Renewable Energy, Solar Energy, Piezoelectric Energy, Arduino Microcontroller, LDR Sensor, IR Sensor, Energy Conservation, Motion Detection, Relay Control, Battery Storage, Automated Lighting System.*

Introduction

The quick growth of world population and cities growing has made for much bigger demand on electricity everywhere [5], [6]. Old types of energy, which are coal, oil and the natural gas, are getting finished and these resources damage the environment [5]. Therefore, it is being noticed by more people that clean and renewable energy is very valuable to use [7]. These ways of making energy reduce use of fossil fuels and cause smarter and better energy use to happen. Renewable types of energy, like an solar power and piezoelectric ways, offer friendly choices for making electrical power and help in the proper running of current systems [1], [7].

Street lights matter for safety of people and cars in both towns and country places. They let everyone see properly when it is dark time. Most old street lighting takes big amount of electricity because the lights are always turned on even when lights are not needed [9]. This gives rise to too much electricity usage and cost to keep them is high. Smart street lighting was developed for these challenges. Smart lights use sensors and automatic controls so that energy is used more efficiently [8],[9].

This work has to do with making and putting in smart streetlight that gets energy from things like sunlight and pressure [1],[7]. The streetlight collects electricity from sun and from pressure and electricity is kept in lead-acid battery with 12 volts to use later [2]. An Arduino microcontroller acts as main controller, taking care of all controlling jobs in the design. The microcontroller takes data from one LDR sensor for checking brightness level and also from one IR sensor that

notices objects or any movement close by [8].

Using sensor information, the Arduino decides to switch on or off the light with a relay module [4]. It turns the light on if there is low light and presence is felt and then turns it off when not required, so energy is not wasted. A regulated supply of power gives controller and parts the voltage that they need for working fine and staying steady [4]. It is also having port for charging a mobile.

This intelligent street lighting system allows saving of energy, needing less electricity to run and pushes for more renewables so that sustainability is kept going for the environment. The quick growth of world population and cities growing has made for much bigger demand on electricity everywhere [5],[6]. Old types of energy, which are coal, oil and the natural gas, are getting finished and these resources damage the environment [5]. Therefore, it is being noticed by more people that clean and renewable energy is very valuable to use [7]. These ways of making energy reduce use of fossil fuels and cause smarter and better energy use to happen. Renewable types of energy, like an solar power and piezoelectric ways, offer friendly choices for making electrical power and help in the proper running of current systems [1],[7].

Survey of Literature

Many researchers have developed smart street lighting systems aimed at reducing energy use and improving lighting efficiency [8],[9]. Traditional streetlights consume a lot of electricity since they remain on all night, regardless of whether there are people or cars nearby. To address this problem, automated lighting systems with sensors and microcontrollers have been proposed.

One common approach uses an LDR (light-dependent resistor) sensor to detect the surrounding light levels. This sensor turns streetlights on at sunset and off at sunrise [8], which cuts down on unnecessary energy use and eliminates the need for manual control.

Besides LDR sensors, motion detection devices like infrared (IR) sensors identify movement from vehicles or pedestrians nearby [8], [9]. When movement is detected, the streetlights turn on, providing light only when necessary. This smart control system saves even more energy by reducing waste.

Additionally, several studies look into street lighting systems powered by renewable energy sources, particularly solar energy [1], [7]. Solar panels convert sunlight into electricity [3], which is stored in batteries for use during times without sunlight, such as at night [2]. Some research also investigates generating energy through mechanical pressure using piezoelectric materials [7].

Existing System

Conventional street lighting usually depends on electricity from the power grid, generated by burning fossil fuels like coal, oil, and natural gas [1]. These lights are either turned on manually or follow fixed schedules. They remain on all night, even when there are few pedestrians or vehicles, causing significant energy waste [4].

Furthermore, traditional lighting systems do not use renewable energy sources and rely completely on a single power supply. This leads to increased electricity use and higher costs for local authorities [3]. Additionally, conventional streetlights do not have smart controls to adjust brightness based on factors like weather or traffic volume [5].

Maintenance is also challenging because problems in these streetlights are usually found through manual checks [6]. Because of these issues, outdated street lighting systems are not efficient and do not fit modern smart city needs [7]. There is a clear need for better, energy-efficient lighting solutions that use renewable energy and automated control technology [3].

Proposed Solution

The Arduino microcontroller serves as the main control unit for the system. It gets signals from an LDR sensor that checks how bright it is outside, and an IR sensor that tells if there are cars or people around [8]. Based on these inputs, the microcontroller uses a relay module to control the street light automatically [4].

When the area around the street light gets dark and someone or something moves, the light turns on by itself. The light switches off when there is enough light or when no one is moving, which helps save energy by avoiding unnecessary use.

The system also has a mobile charging port, so users can charge their electronic devices whenever they need to. By using renewable energy sources along with smart lighting systems that turn on and off automatically, the system helps save energy and promotes the growth of ecofriendly smart cities [7],[10].

Methodology and Components

The smart street lighting system works by combining renewable energy sources, storage for that energy, sensors to gather data, and controls that turn the lights on and off automatically [1], [7]. Solar panels and piezoelectric modules create electricity, which is then kept in a battery [1], [3]. The energy that is stored is used to power the Arduino microcontroller and the LED street light [4].

Sensors continuously monitor environmental conditions. The LDR sensor checks how bright it is around it, and the IR sensor finds out if there are moving things like cars or people nearby [8],[9]. Based on the information it receives, the Arduino determines if the street light needs to be turned on or off [4].

Functional Flow

Solar Panel / Piezoelectric Generator → Battery Storage → Arduino Controller → Sensors (LDR & IR) → Relay Module → LED Street Light [4],[7]

1. The solar panel changes sunlight into electricity [1],[3], and the piezoelectric plate makes electricity from mechanical pressure [7].
2. The electricity made from both sources is kept in a 12-volt lead-acid battery [2].
3. The battery provides power to a regulated power supply, which changes the voltage to the right level that the Arduino microcontroller needs [4].
4. The LDR keeps checking the amount of light around it to tell whether it's day or night.
5. During the day, when the LDR senses enough light, the Arduino turns the street light off [8].
6. At night, when the light gets too dark and drops below a certain level, the Arduino turns on the street lights [8].
7. The infrared sensor finds out if there are cars or people on the road [9].
8. When the system detects movement, the Arduino gives a signal to the relay to control it [4].
9. The relay turns on the 12-volt LED street light by getting power from the battery [4].
10. When there is no movement detected, the Arduino turns off the relay, which turns off the street light to save energy [8], [9].
11. The battery's stored energy can also be used to offer a portable charging service [10].

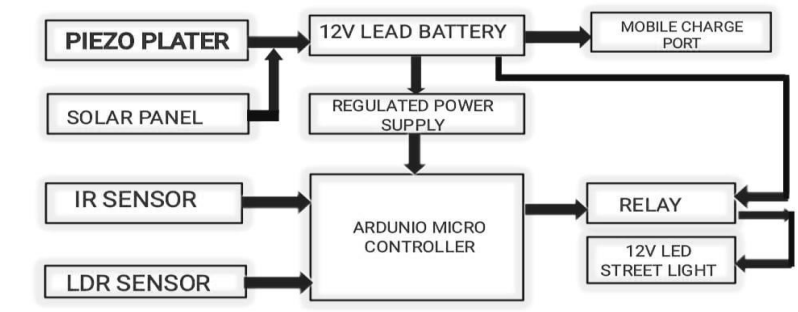

Fig.1:Block diagram of the smart street lighting

Component used and described:**Solar Panel**

The solar panel uses the photovoltaic effect to turn sunlight into electricity [1],[3]. It serves as the primary source of renewable energy for the system. The electricity produced is used to charge the battery and run the street lights.

Piezoelectric Sensor / Plate

A piezoelectric sensor generates electricity when you press it or move it back and forth [7]. The weight from a car or a person walking will generate a little bit of electricity in this project. This electricity will be used to charge the battery and will increase the efficiency of its usage.

12V Lead-Acid Battery

The battery will store the energy generated from the solar panel and piezoelectric sensor [2]. The battery will provide necessary power to the Arduino controller and street light as required. The battery will ensure smooth operation of this project even in dark or low sunlight conditions.

Arduino Microcontroller

The Arduino will act as a main controller in this project. The Arduino will receive input from sensors and automatically control the street light to turn it on/off [8]. The Arduino will use input from sensors to send commands to the relay module to turn the street light on/off [4].

LDR Sensor (Light-Dependent Resistor)

The LDR sensor will measure the brightness of light in the environment [8]. The LDR will vary its resistance depending on the level of light in the environment. This will help determine whether it is day or night.

IR Sensor

The infrared sensor detects the presence of vehicles or pedestrians near the street light [9]. The infrared sensor sends a signal to the Arduino when it detects movement. This saves energy by illuminating the street light only when necessary.

Relay Module

The relay module acts as an electronic switch that controls the street light [4]. It enables the Arduino to turn the LED light on or off while safely isolating the high-voltage lighting circuit from the control circuitry.

LED Street Light

The LED street light provides excellent illumination while consuming less electricity and operating efficiently [10]. LEDs are advantageous because they maintain high brightness for a longer period and require less power than conventional street lights, contributing to greater overall energy efficiency of the system.

Voltage Regulator / Power Supply

The voltage regulator ensures a stable and safe power supply for the Arduino and sensors [4]. It prevents damage to electronic components during voltage fluctuations, thereby enhancing the system's reliability and performance.

Mobile Charging Port

The mobile charging port enables users to recharge their phones by utilizing the energy stored in the battery [10]. This addition enhances the street lighting system with practical features, proving particularly useful in public areas or during emergencies.

Results and Discussion

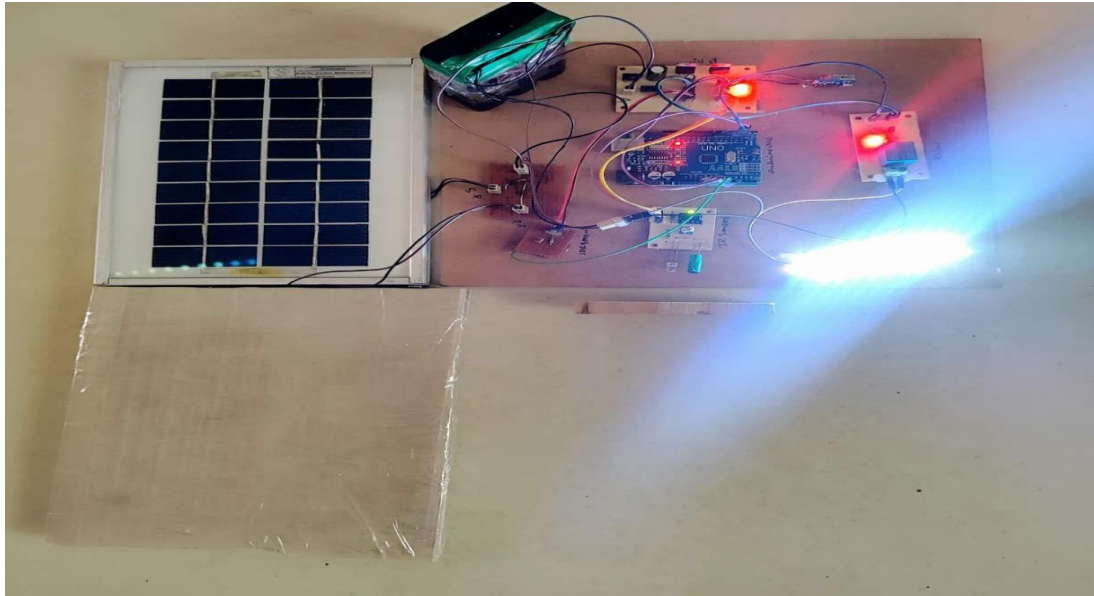

Fig. 2:Prototype setup of the smart street lighting

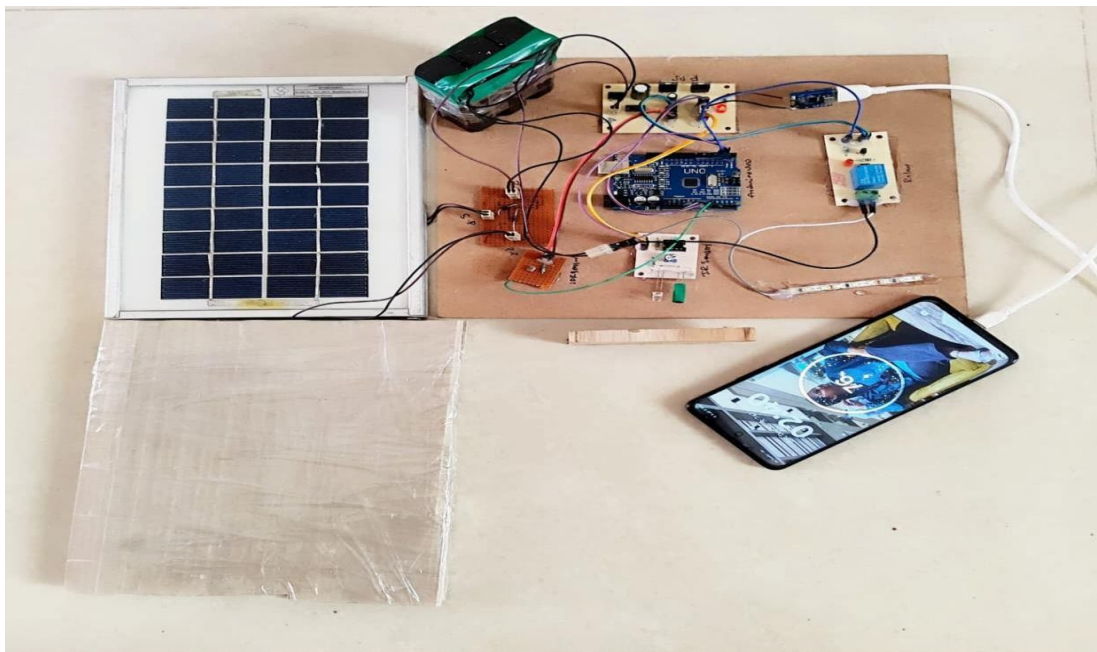

Fig. 3:Prototype setup of mobile charging port

The effectiveness and performance of the smart street lighting system were evaluated in a range of environmental settings. The prototype demonstrated that it employs energy-saving techniques, has automatic control features, and functions effectively with renewable energy sources [7], [10].

The LDR sensor detected a powerful light signal from the sun during the day. The LED street light was prevented from consuming additional power by the Arduino microcontroller. This demonstrated that the algorithm can distinguish between day and night without human intervention [8].

The mechanism began to function when the light dimmed in the evening or at night. The infrared sensor continued to scan its surroundings for any close vehicles or persons. The relay immediately turned on the LED street light after the Arduino detected movement and transmitted a signal to the relay module. After a short while, the street light went out

when the thing had moved away and there was no further movement. By ensuring that the light was only switched on when necessary, this action significantly reduced energy loss [8], [9]. When sunshine was present, the solar panel produced electricity effectively. When pressure was applied to the piezoelectric sensor, it generated additional electricity [1], [7]. The system's main power source during nighttime was a 12V lead-acid battery that stored the generated energy [2]. The battery provided steady and continuous power to the Arduino, sensors, and LED street light [4].

The LED street lighting offers adequate illumination while using less electricity than older street lights. The use of LEDs leads to a longer-lasting lighting system that is more reliable [10].

Another important component studied was the mobile charging port included in the system. The battery's stored energy can be used to recharge small devices like mobile phones, which adds to the system's usefulness.

Experimental results show that the smart street lighting system works well and performs as expected. The system reduces electricity consumption, improves energy management, and supports the use of clean, renewable energy sources [5], [7]. These benefits make the system suitable for smart city projects, highways, parking areas, and rural roads, especially in places where saving energy and promoting environmental sustainability are top priorities [10].

Conclusion

This study pushes the sphere of learning into the world of the use with the purpose of categorizing medical images with the help of the advanced Xception model. The findings of the discoveries do not contribute to our intelligence and medical imaging but also opens the door to better approaches to diagnostics in health-care. Our paper has presented a methodology-driven and objective data-based research that revealed that the Xception model is superior to the old techniques and methods in detecting patterns in images with higher accuracy and faster performance. This enhancement highlights the capability of deep learning algorithms in improving imaging in the detection of early diseases and improving patient care.

Even though our findings are encouraging it presents opportunities to investigate. One of the priorities of the further research is the improvement of the models precision with datasets. The use of data sources might develop the capacities of the models and give a more detailed picture of medical conditions. Overall, this paper highlights the way deep learning is transforming imaging. The Xception model can be tested and validated as being effective in diagnostics. Brings the path of new studies that open the doors to the innovative AI based healthcare solutions.

Acknowledgment

The authors wish to admit their design companion and the faculty members for their continual support, guidance, and stimulant throughout the design.

The authors also gratefully admit the laboratory staff for furnishing essential coffers and backing with the specialized aspects of the design. They extend thanks to classmates and musketeers for their support and stimulant, which were necessary in the consummation of this design.

References

1. T. Markvart, Solar Electricity, John Wiley & Sons, 2000.
2. D. Linden and T. B. Reddy, Handbook of Batteries, McGraw-Hill, 2011.
3. A. Luque and S. Hegedus, Handbook and Photovoltaic Science and Engineering, Wiley, 2011.
4. M. H. Rashid, Power Electronics: Circuits, Devices, and Applications, Pearson Education, 2018.
5. International Energy Agency (IEA), Renewables 2023: Analysis and Forecast to 2028, IEA Publications,

- 2023.
6. REN21, Renewables Global Status Report, REN21 Secretariat, Paris, 2022.
 7. N. Kumar, R. Singh, and S. C. Kaushik, "Solar photovoltaic technology: Current status and future developments," *Energy Reports*, vol. 6, pp. 202–212, 2020.
 8. A. A. Kulkarni and K. N. Patil, "Smart street lighting system using Arduino and sensors," *International Journal of Engineering Research and Technology (IJERT)*, vol. 9, no. 5, pp. 512– 516, 2020.
 9. P. R. Pathak, S. Pandey, and A. Kumar, "Energy efficient smart street lighting system using IoT," *International Journal of Scientific and Engineering Research*, vol. 10, no. 6, pp. 1201– 1205, 2019.
 10. R. Kumar, S. Sharma, and P. Chauhan, "Solar powered lighting system for sustainable urban infrastructure," *Renewable Energy Journal*, vol. 145, pp. 1125–1136, 2020.